

NEW GRAVURE TV MEUBEL 100CM

NEW TV-MÖBEL 100CM - NEW MEUBLE TV 100CM - NEW TV-STAND 100CM

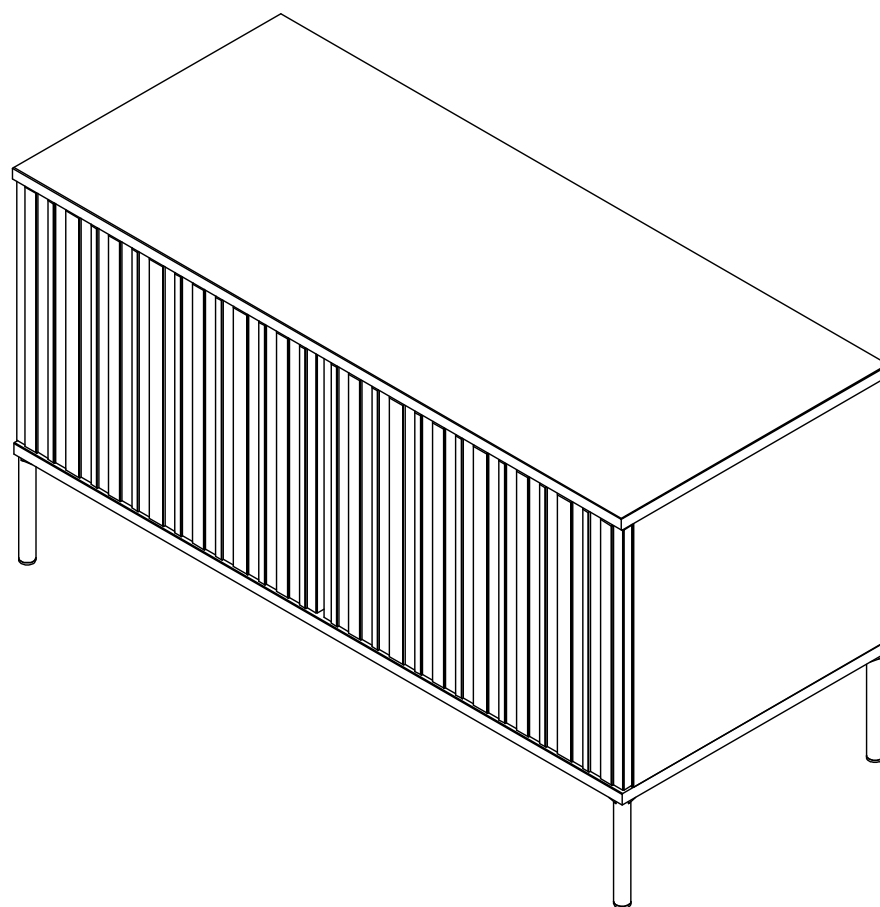

MADE BY
wood

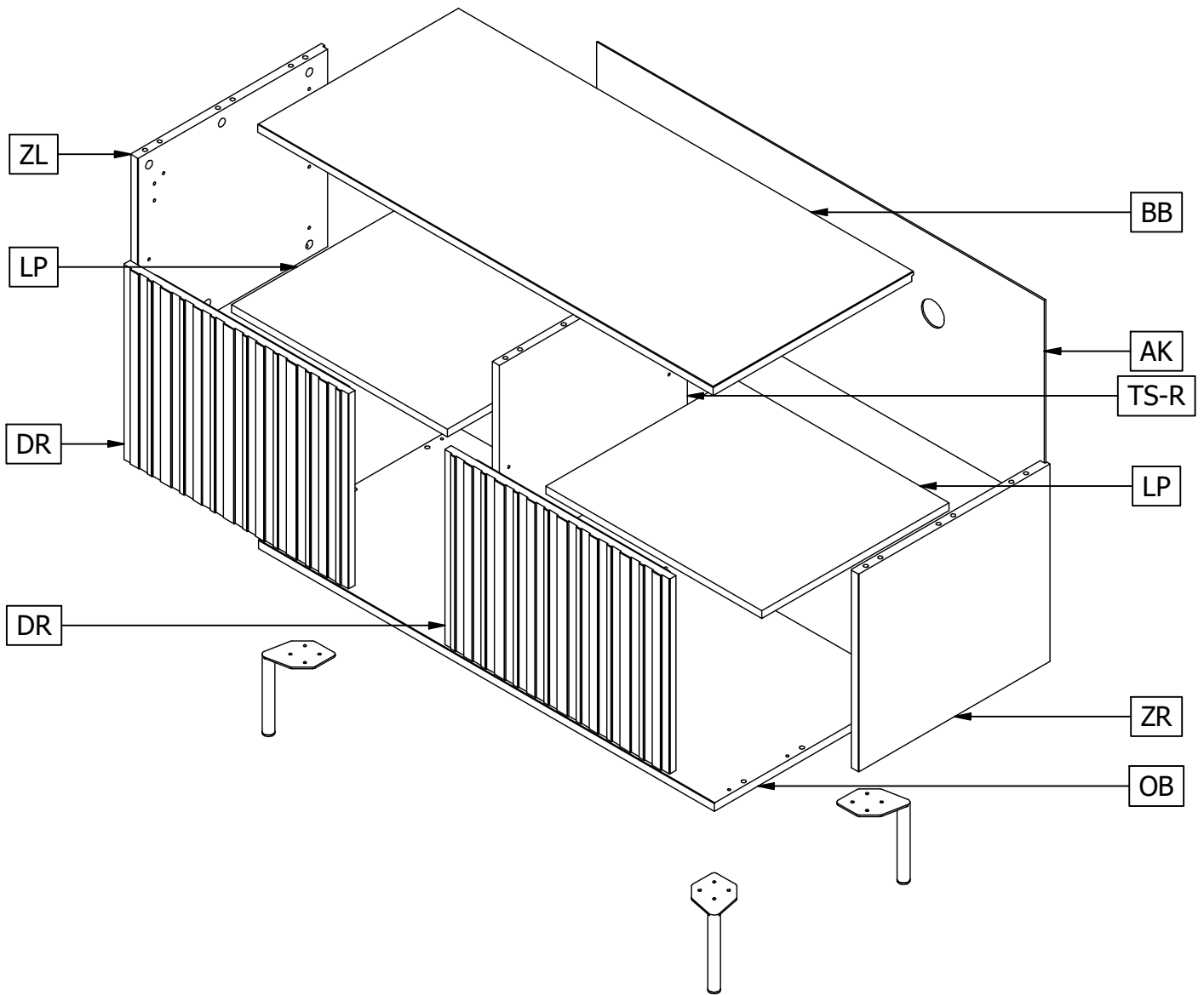

Qty	Code	Thickness	Length	Width
1	AK	3	984	394
1	BB	17	1001	440
2	DR	18	371	495
2	LP	15	474	411
1	OB	17	1001	438
1	TS-R	15	376	413
1	ZL	17	376	420
1	ZR	17	376	420

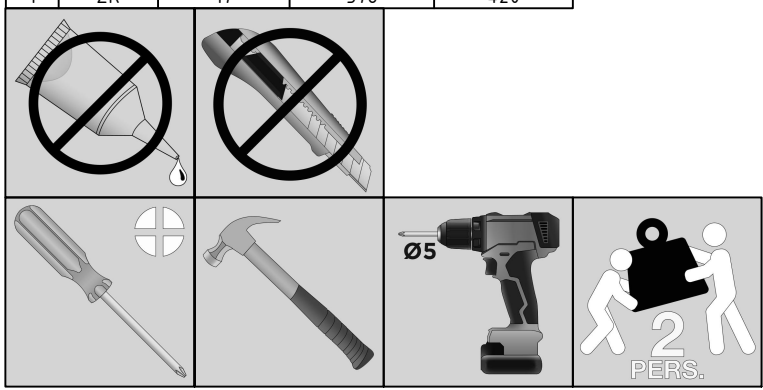

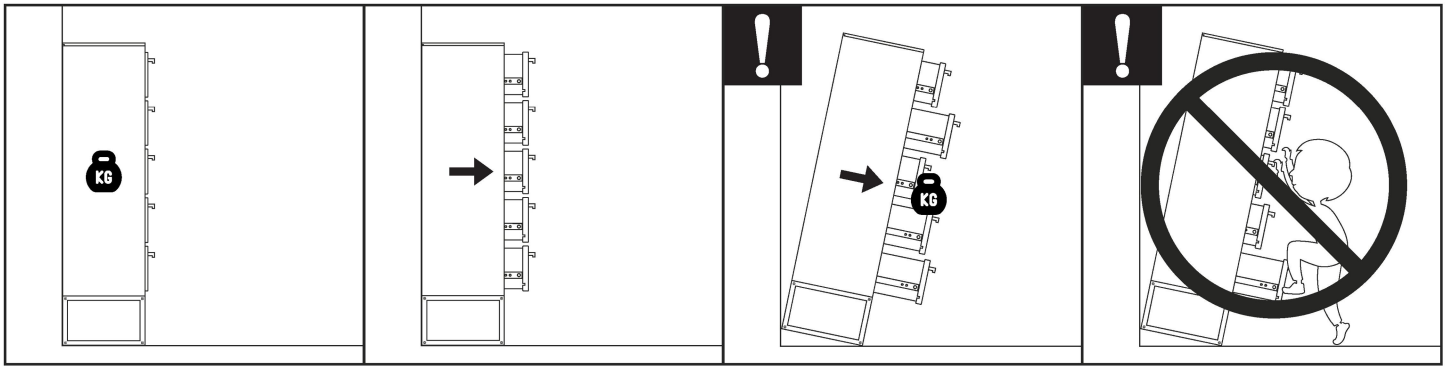

NEDERLANDS OMVALBEVEILIGING

Gebruik ABSOLUUT het meegeleverde kantelbeslag om het meubel aan de muur te bevestigen en voorkom letsel door omvallen. Voorkom ook dat kinderen op lades, deuren of planken klimmen. Plaats zware voorwerpen altijd onderin en zet ze nooit bovenop het meubel.

EIGENSCHAPPEN HOUT

Hout is een natuurproduct met unieke kleur en uitstraling. Noesten en kwasten zijn zichtbaar. Onder invloed van licht en warmte kan het uiterlijk veranderen, afhankelijk van de ruimte. Afwijkingen ten opzichte van showroommodellen zijn normaal.

KLEUR

Eiken meubelen (onbehandeld): behandelen met olie, lak, beits of was voor langdurigheid van het meubel. Test de kleur op een onzichtbaar deel en volg gebruiksaanwijzing. Bescherm bovenbladen tegen direct zonlicht.

Grenen meubelen (ongeborsteld en geborsteld): Vooraf behandeld met UV-werende laag en semidekkende lak. Looizuur in grenen kan onder invloed van licht en warmte zichtbaar worden. De lak vertraagt dit proces. Overschilderbaar met waterverdunbare lak. Volg gebruiksaanwijzing.

MEUBELMONTAGE

Monteer het meubel zo snel mogelijk na opening. Lees de handleiding zorgvuldig. Als directe montage niet mogelijk is, bewaar het meubel liggend op kamertemperatuur.

SERVICE EN GARANTIE

Bij productgebreken, neem contact op met het aankoopadres. Bewaar aankoopbon, originele verpakking en handleiding. Na evaluatie van het gebrek worden mogelijk onderdelen gerepareerd of vervangen. Onderdelen worden op de handleiding aangegeven met codes. Gebreken vallen binnen twee jaar onder de fabrieksgarantie, tenzij veroorzaakt door foutieve behandeling of negeren van montage-instructies.

ONDERHOUD

Houd het meubel schoon met een katoenen doek. Verwijder vlekken direct met een vochtige doek en droog na. Wrijf altijd in de richting van de houtnerf. Gebruik geen schurende middelen. Plaats viltjes onder accessoires om krassen en kringen te voorkomen.

ENGLISH TOPPLE PROTECTION

ABSOLUTELY use the supplied anti-tip device to secure the furniture to the wall and prevent injury from tipping. Also, ensure that children do not climb on drawers, doors, or shelves. Always place heavy objects at the bottom and never on top of the furniture.

WOOD CHARACTERISTICS

Wood is a natural product with a unique color and appearance. Knots and knots are visible. Under the influence of light and heat, the appearance may change depending on the space. Deviations from showroom models are normal.

COLOR

Oak furniture (untreated): treat with oil, lacquer, stain, or wax for the longevity of the furniture. Test the color on an invisible part and follow the instructions. Protect tabletops from direct sunlight.

Pine furniture (unbrushed and brushed): Pre-treated with a UV-resistant layer and semi-opaque lacquer. Tannic acid in pine may become visible under the influence of light and heat. The lacquer slows down this process. Paintable with water-dilutable lacquer. Follow the instructions.

FURNITURE ASSEMBLY

Assemble the furniture as soon as possible after opening. Read the manual carefully. If immediate assembly is not possible, store the furniture lying down at room temperature.

SERVICE AND WARRANTY

In case of product defects, contact the place of purchase. Keep the purchase receipt, original packaging, and manual. After evaluating the defect, parts may be repaired or replaced. Parts are indicated with codes in the manual. Defects are covered by the two-year factory warranty unless caused by improper treatment or ignoring assembly instructions.

MAINTENANCE

Keep the furniture clean with a cotton cloth. Remove stains immediately with a damp cloth and dry afterward. Always rub in the direction of the grain. Do not use abrasive agents. Place felt pads under accessories to prevent scratches and rings.

FRANÇAIS PROTECTION CONTRE LE RENVERSEMENT

Utilisez ABSOLUMENT le dispositif anti-basculement fourni pour fixer le meuble au mur et éviter les blessures dues au renversement. Veillez également à ce que les enfants ne grimpent pas sur les tiroirs, les portes ou les étagères. Placez toujours les objets lourds en bas et jamais au-dessus du meuble.

CARACTÉRISTIQUES DU BOIS

Le bois est un produit naturel avec une couleur et une apparence uniques. Les nœuds et les défauts sont visibles. Sous l'influence de la lumière et de la chaleur, l'apparence peut changer en fonction de l'espace. Les écarts par rapport aux modèles d'exposition sont normaux.

COULEUR

Meubles en chêne (non traités): traiter avec de l'huile, du vernis, de la teinture ou de la cire pour la longévité du meuble. Testez la couleur sur une partie invisible et suivez les instructions. Protégez les plateaux de table de la lumière directe du soleil. Meubles en pin (non brossé et brossé): prétraités avec une couche résistante aux UV et un vernis semi-opaque. L'acide tannique dans le pin peut devenir visible sous l'influence de la lumière et de la chaleur. Le vernis ralentit ce processus. Peut être repeint avec un vernis diluable à l'eau. Suivez les instructions.

ASSEMBLAGE DES MEUBLES

Montez le meuble dès que possible après l'ouverture. Lisez attentivement le manuel. Si le montage immédiat n'est pas possible, conservez le meuble allongé à température ambiante.

SERVICE ET GARANTIE

En cas de défauts du produit, contactez le lieu d'achat. Conservez le reçu d'achat, l'emballage d'origine et le manuel. Après évaluation du défaut, des pièces peuvent être réparées ou remplacées. Les pièces sont indiquées par des codes dans le

manuel. Les défauts sont couverts par la garantie d'usine de deux ans, sauf s'ils sont causés par un traitement incorrect ou l'ignorance des instructions d'assemblage.

ENTRETIEN

Gardez le meuble propre avec un chiffon en coton. Enlevez les taches immédiatement avec un chiffon humide et séchez ensuite. Frottez toujours dans le sens du grain du bois. N'utilisez pas de produits abrasifs. Placez des patins en feutre sous les accessoires pour éviter les rayures et les cercles.

DEUTSCH KIPPSICHERUNG

Verwenden Sie UNBEDINGT die mitgelieferte Kippsicherung, um das Möbelstück an der Wand zu befestigen und Verletzungen durch Umkippen zu vermeiden. Stellen Sie außerdem sicher, dass Kinder nicht auf Schubladen, Türen oder Regale klettern. Platzieren Sie schwere Gegenstände immer unten und niemals oben auf dem Möbelstück.

HOLZEIGENSCHAFTEN

Holz ist ein Naturprodukt mit einzigartiger Farbe und Ausstrahlung. Astlöcher und Äste sind sichtbar. Unter dem Einfluss von Licht und Wärme kann sich das Erscheinungsbild je nach Raum ändern. Abweichungen von Ausstellungsmodellen sind normal.

FARBE

Eichenmöbel (unbehandelt): behandeln Sie mit Öl, Lack, Beize oder Wachs für die Langlebigkeit des Möbelstücks. Testen Sie die Farbe an einer unsichtbaren Stelle und befolgen Sie die Anweisungen. Schützen Sie Tischplatten vor direktem Sonnenlicht. Kiefernmöbel (ungeschliffen und geschliffen):

Vorbehandelt mit UV-beständiger Schicht und halbdeckendem Lack. Gerbstoffe im Kiefernholz können unter dem Einfluss von Licht und Wärme sichtbar werden. Der Lack verlangsamt diesen Prozess. Überstreichbar mit wasserlöslichem Lack. Befolgen Sie die Anweisungen.

MONTAGE DER MÖBEL







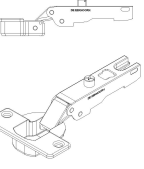
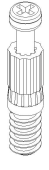
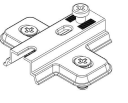

Montieren Sie das Möbelstück so schnell wie möglich nach dem Öffnen. Lesen Sie die Anleitung sorgfältig durch. Wenn eine sofortige Montage nicht möglich ist, lagern Sie das Möbelstück liegend bei Raumtemperatur.

SERVICE UND GARANTIE

Im Falle von Produktmängeln wenden Sie sich an den Kaufort. Bewahren Sie den Kaufbeleg, die Originalverpackung und die Anleitung auf. Nach Bewertung des Mangels können Teile repariert oder ersetzt werden. Teile sind in der Anleitung mit Codes gekennzeichnet. Mängel fallen innerhalb von zwei Jahren unter die Herstellergarantie, es sei denn, sie wurden durch unsachgemäße Behandlung oder Nichtbeachtung der Montageanweisungen verursacht.

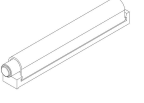
PFLEGE

Halten Sie das Möbelstück mit einem Baumwolltuch sauber. Entfernen Sie Flecken sofort mit einem feuchten Tuch und trocknen Sie danach ab. Reiben Sie immer in Richtung der Holzmaserung. Verwenden Sie keine scheuernden Mittel. Legen Sie Filzunterlagen unter Accessoires, um Kratzer und Ringe zu vermeiden.

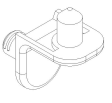
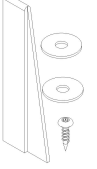
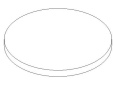
18	Ø15mm	AC000102 	4	Ø35mm/0mm	AC000423 
18	24mm	AC000103 	4	0MM	AC000426 
4	M4X27 Ø5	AC000154 	18	8x35mm	AC000601 
4	M4x15mm	AC000155 	2	Push To Open	AC003012 
4	3x15mm	AC000201 	4	H=150mm	AC005027 
24	4x16mm	AC000204 			
25	Ø1.4x25mm	AC000316 			
8	Ø5mm	AC000349 			
1	Safety Strip	AC000356 			
18	Ø14mm	AC000369- 			

1

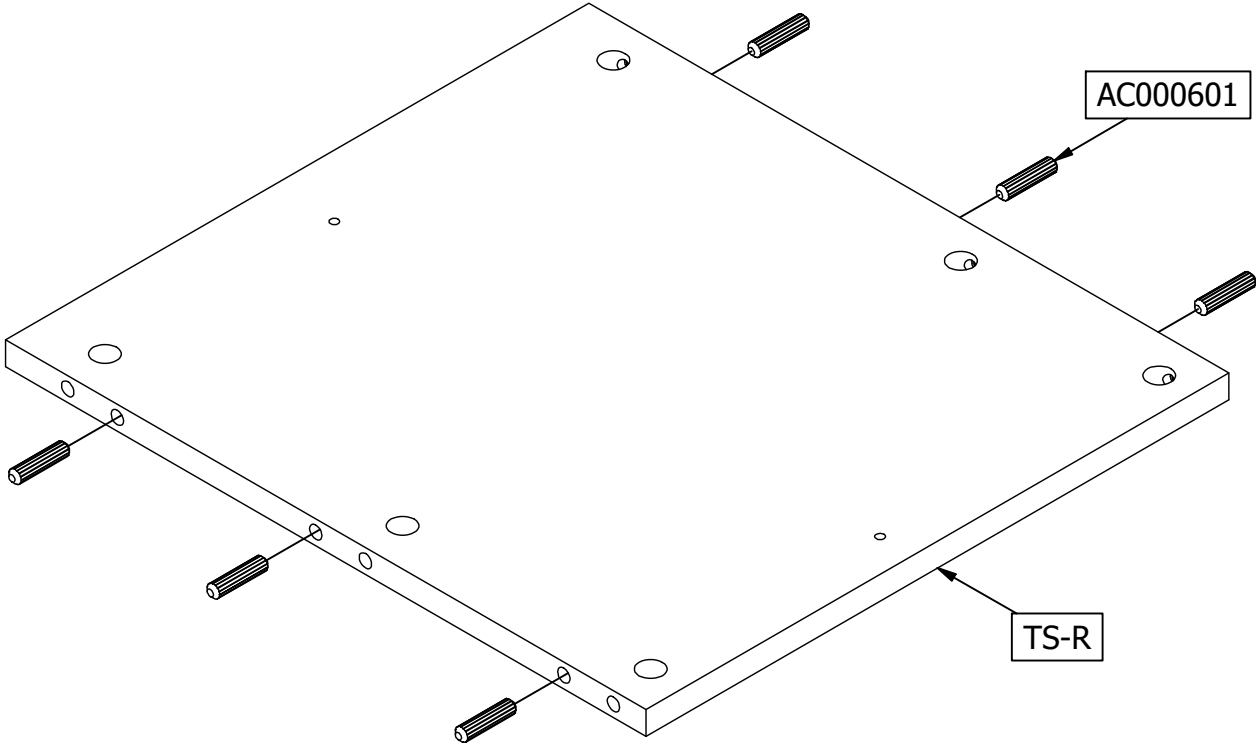
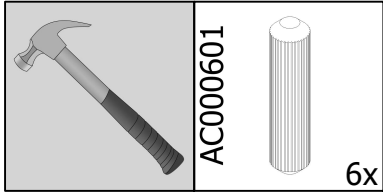

2

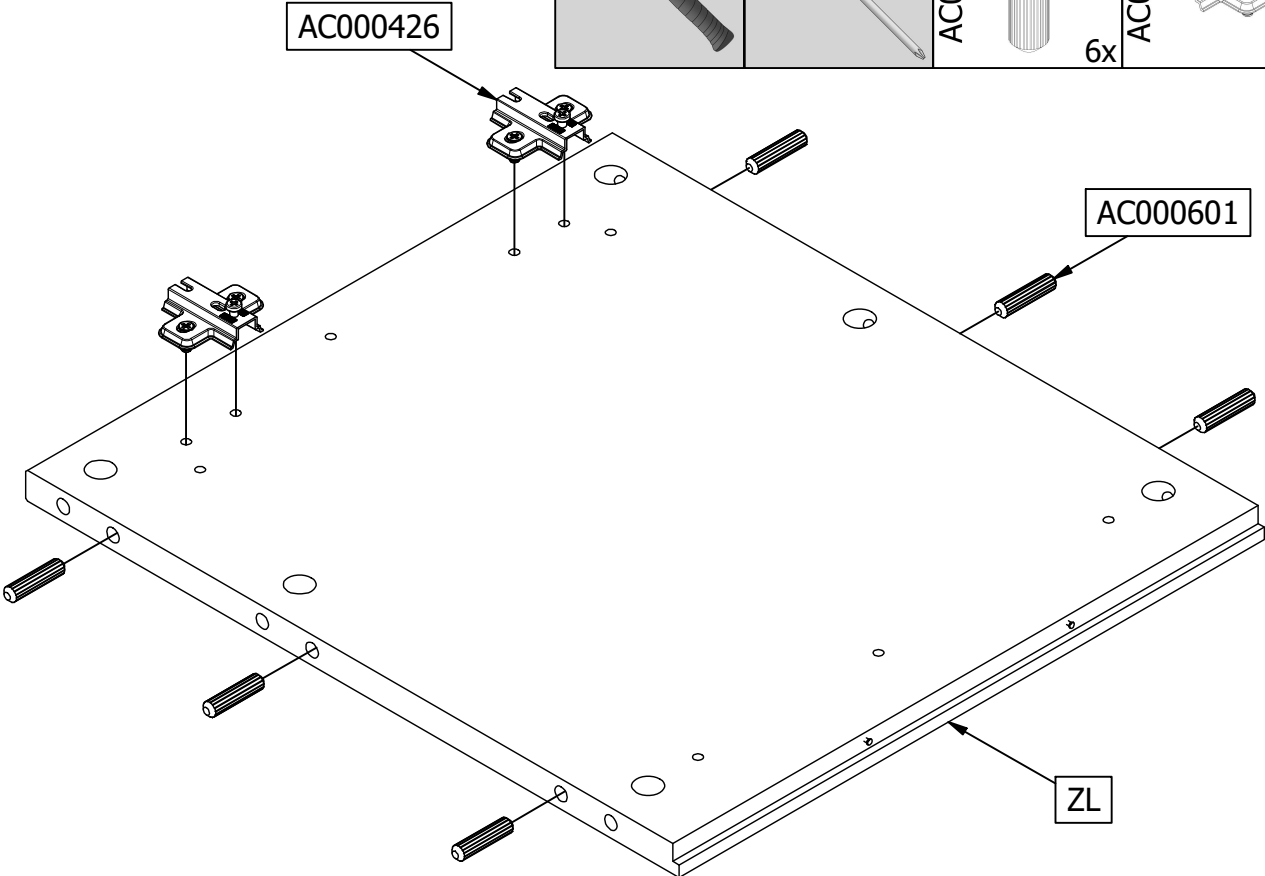
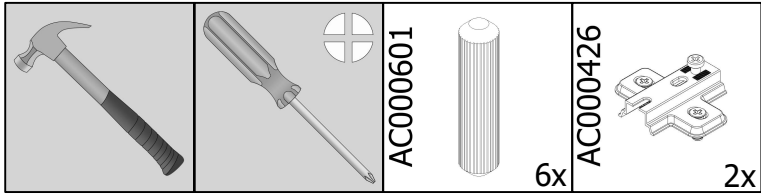

3

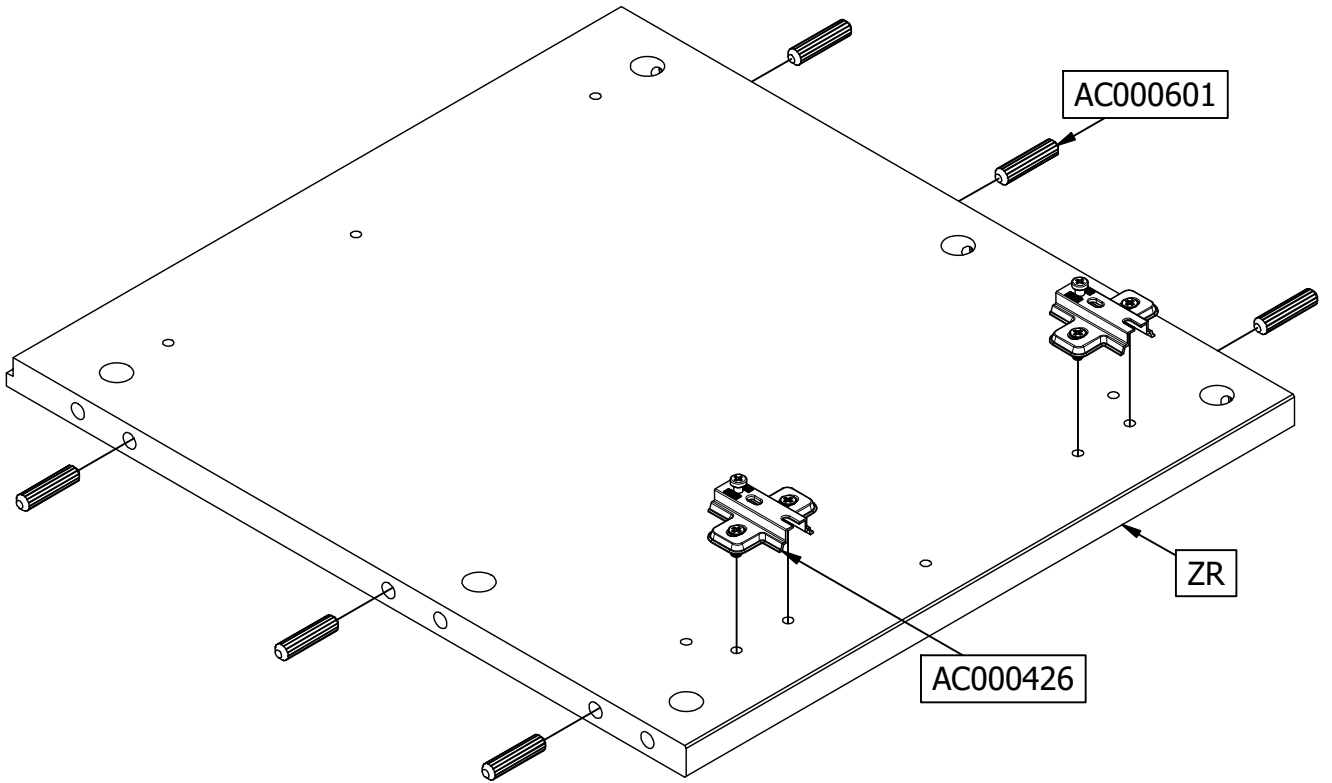
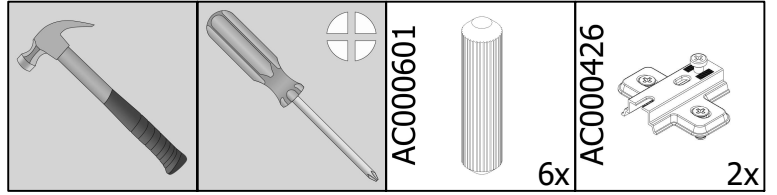

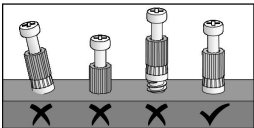
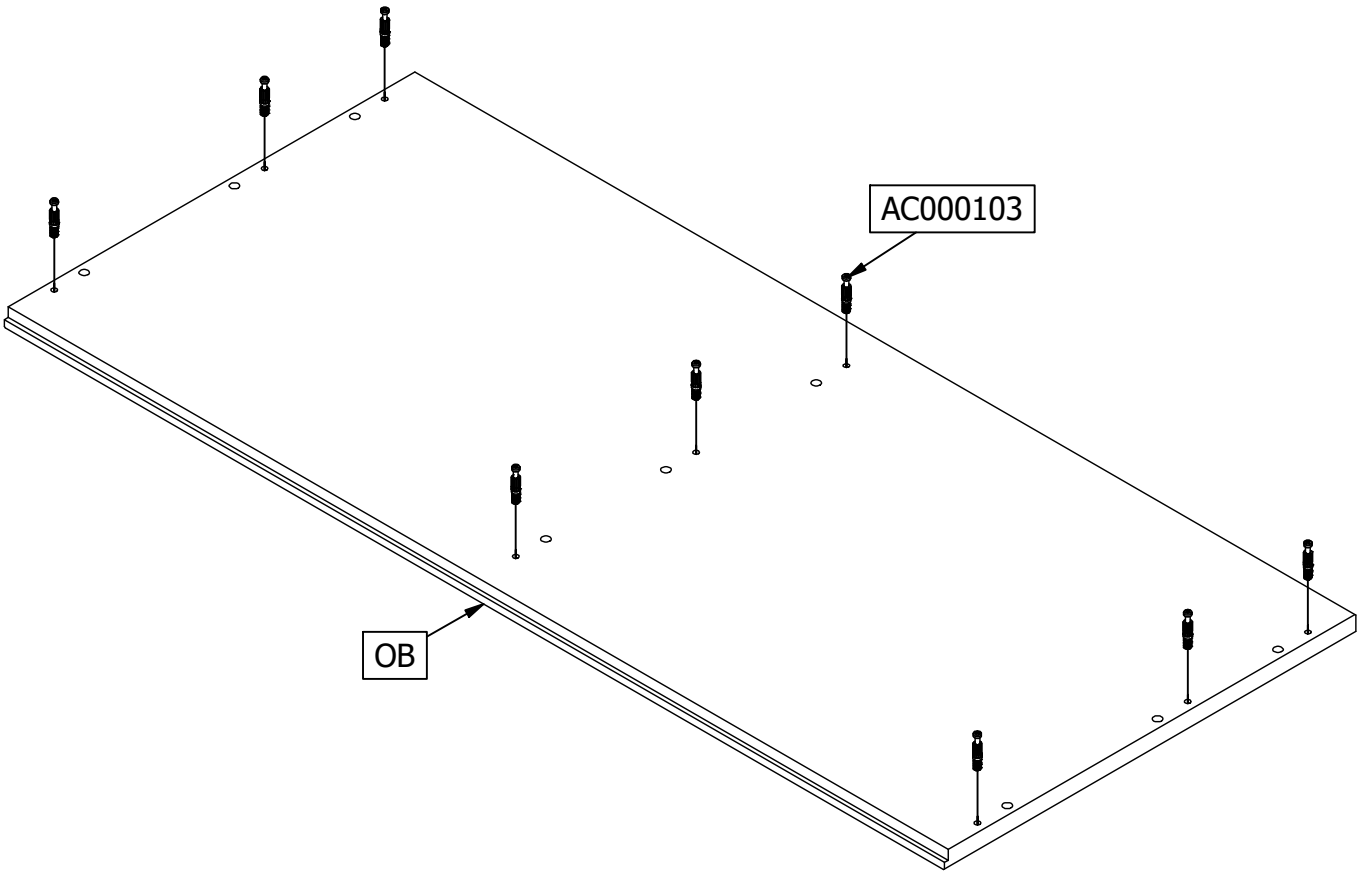
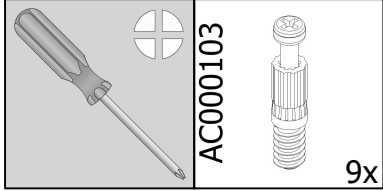

4

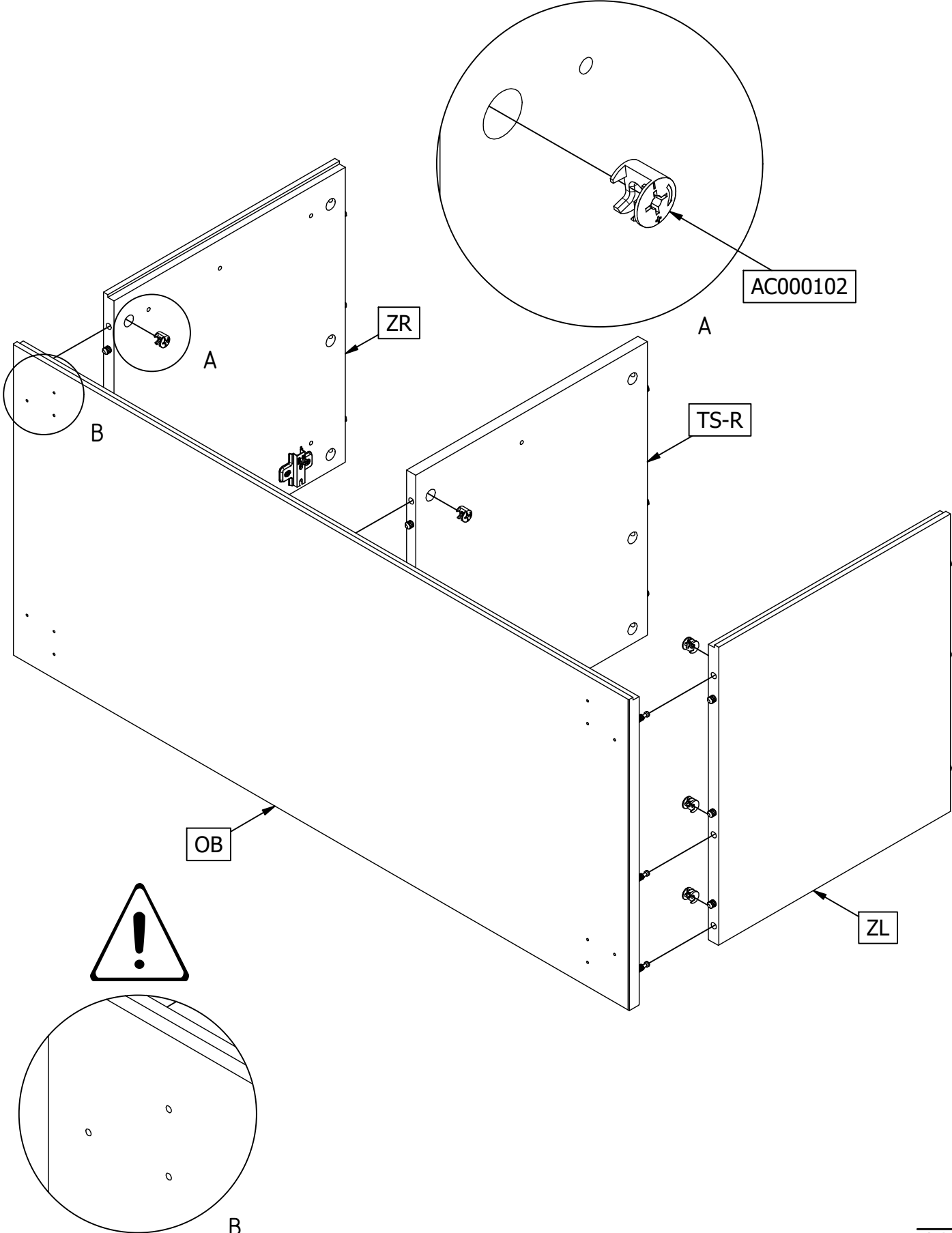
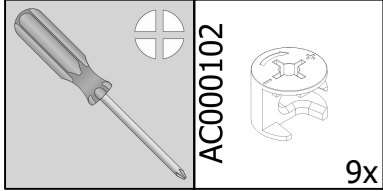

5

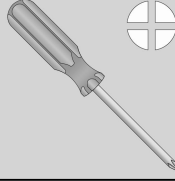
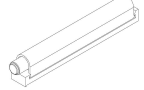

6

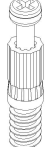
	AC003012		2x	AC000201		4x	AC000103		9x
---	----------	--	----	----------	---	----	----------	---	----

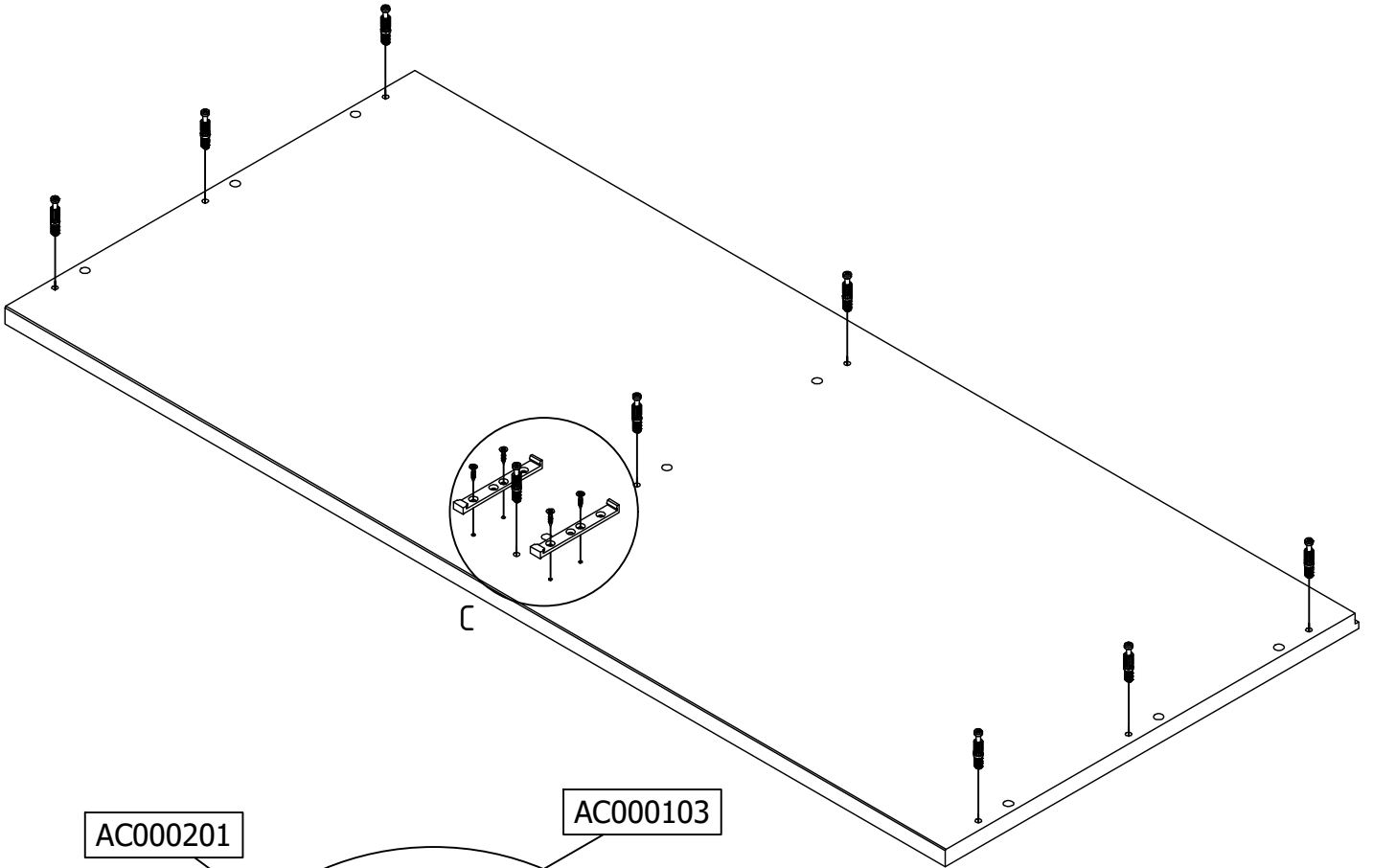

AC000201

AC000103

AC003012

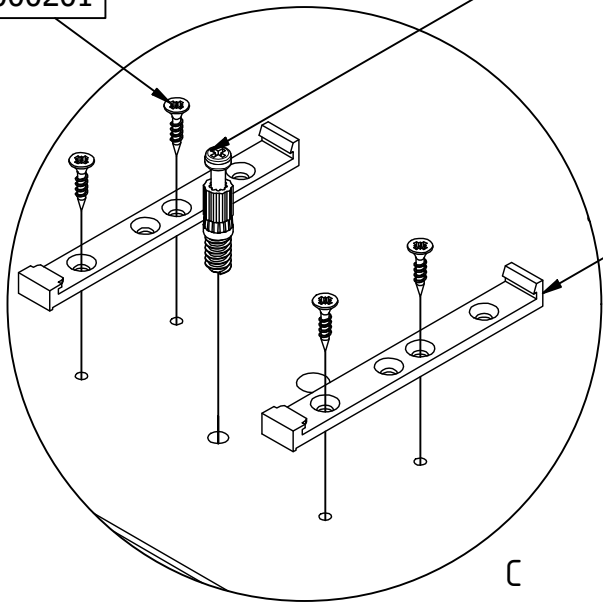

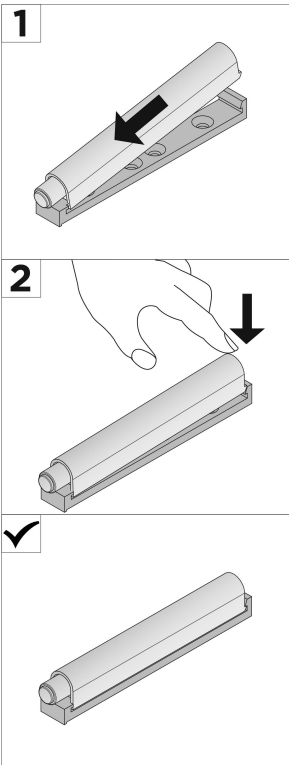
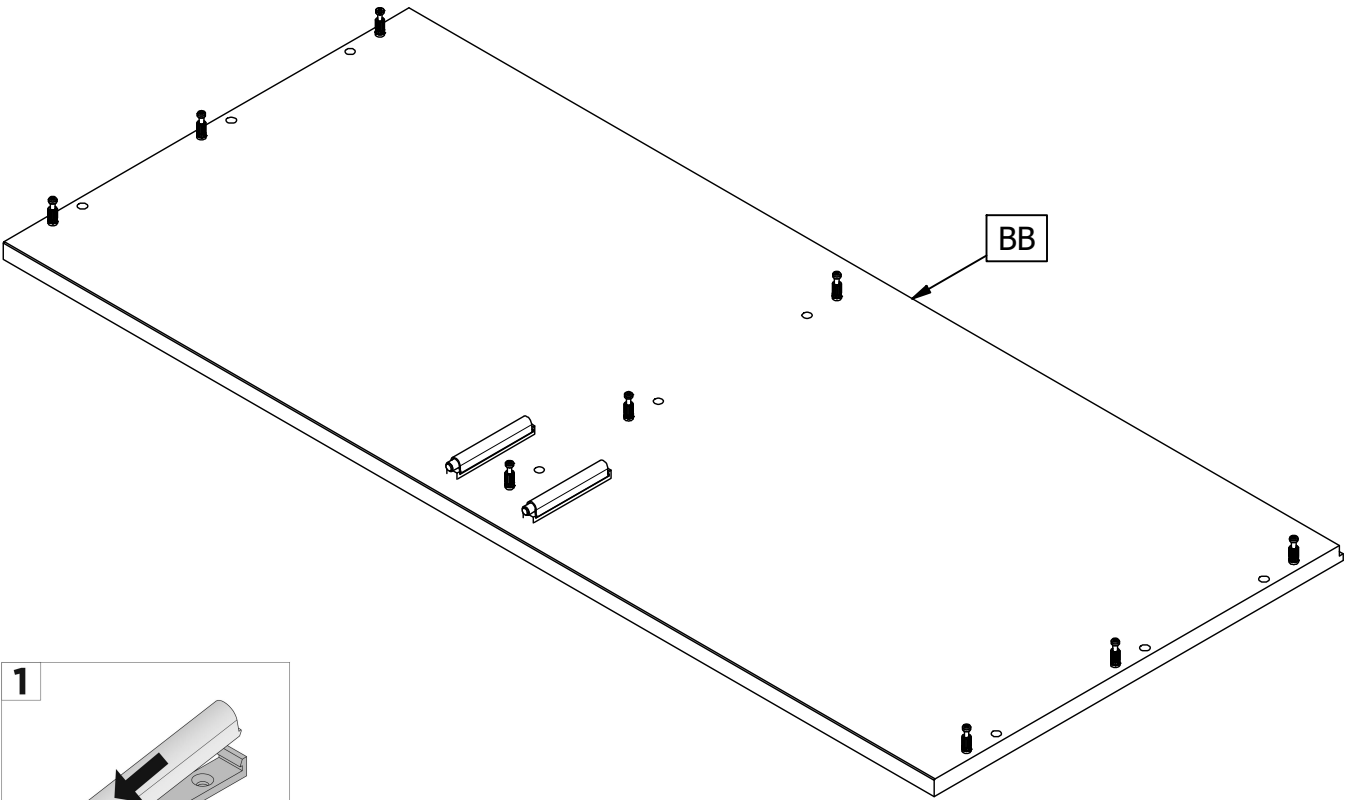
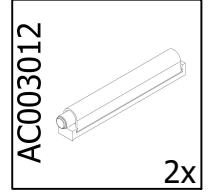

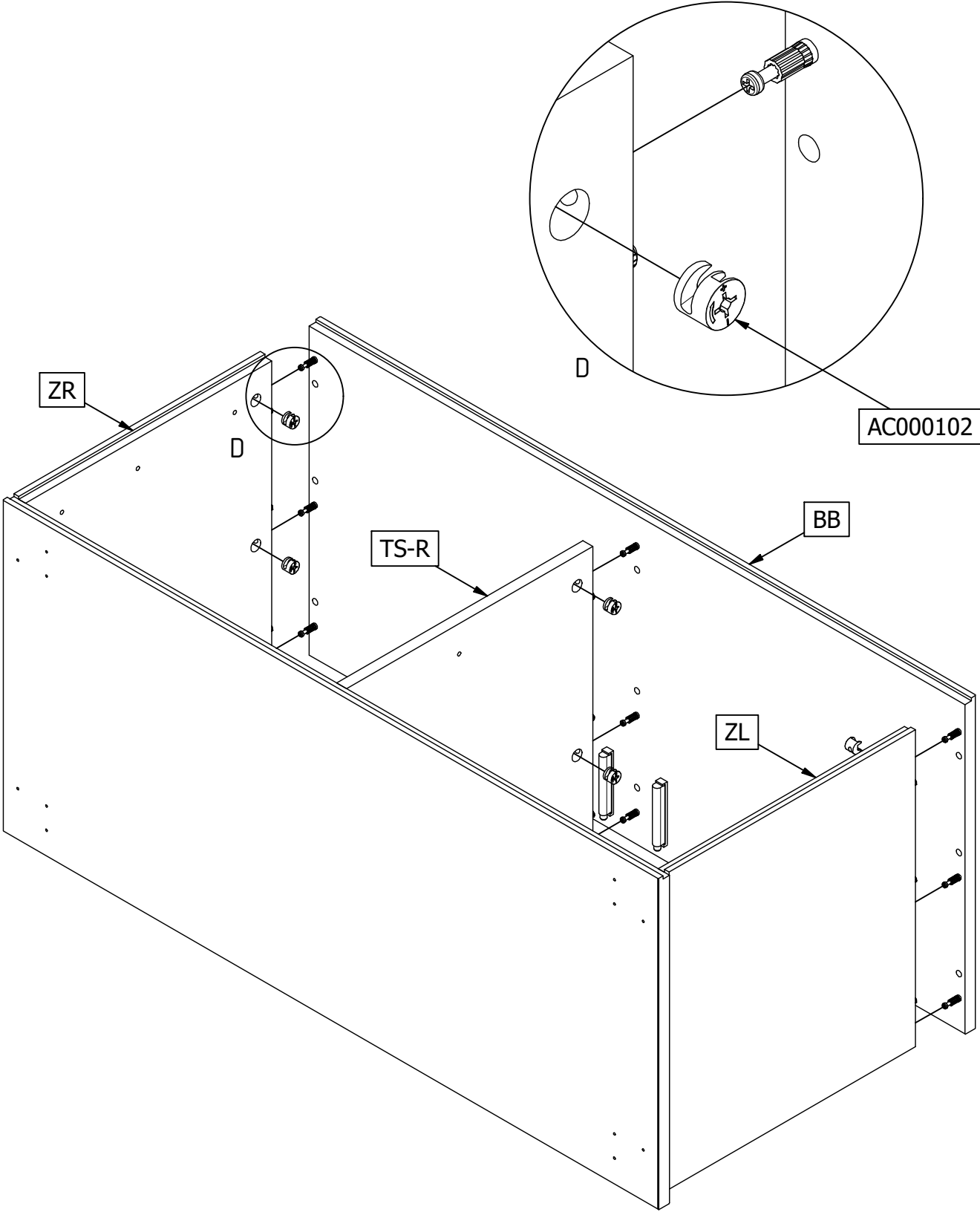
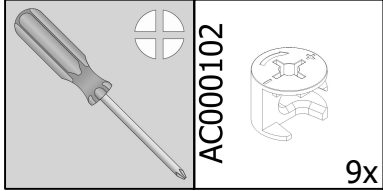

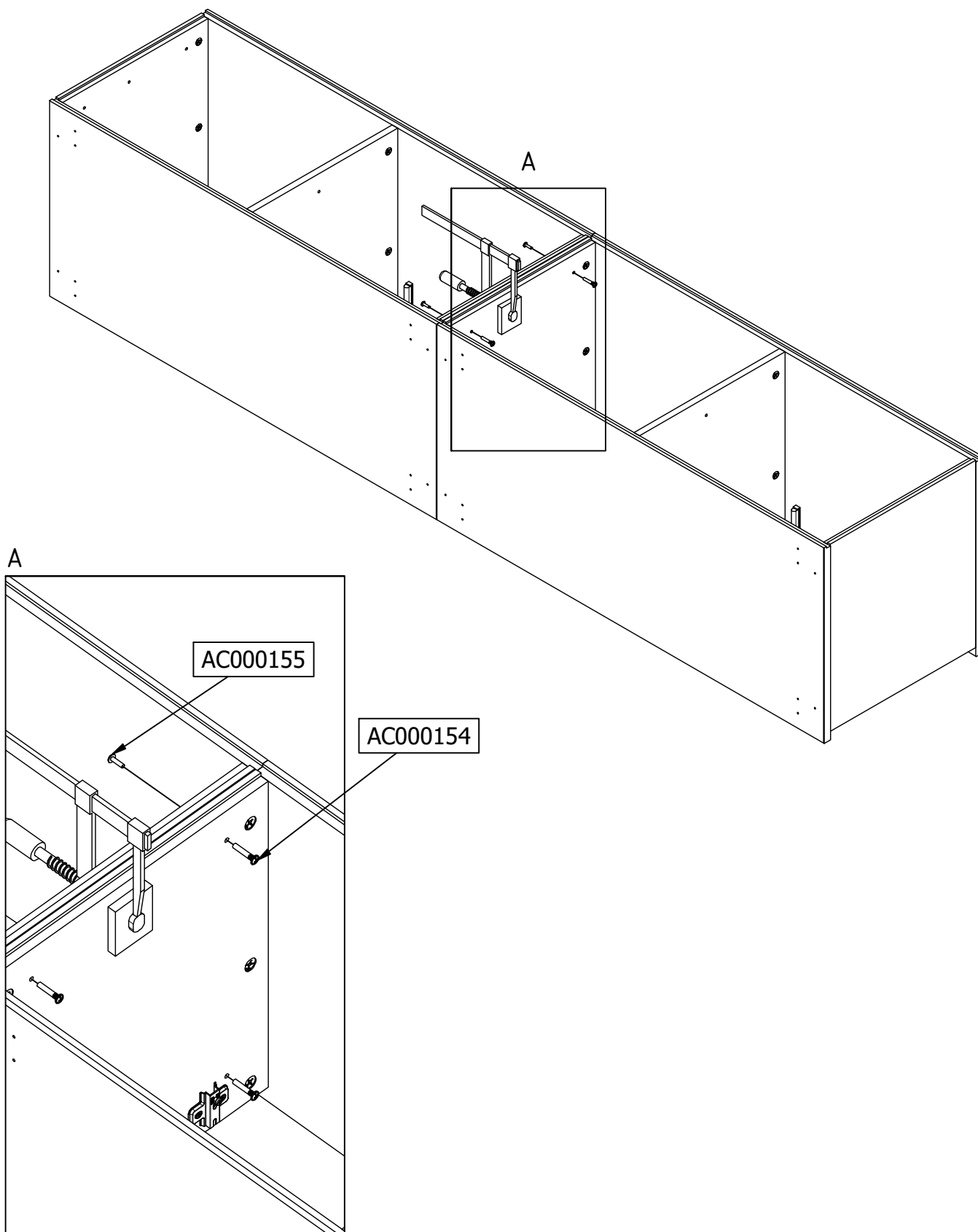
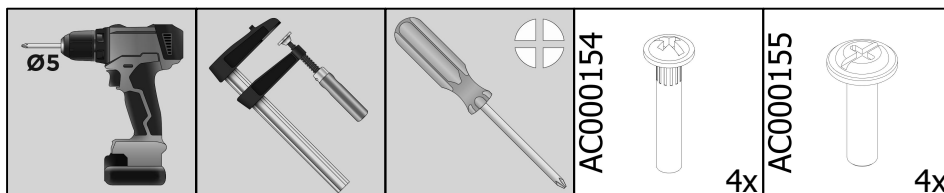

1
OPTIE - OPTION

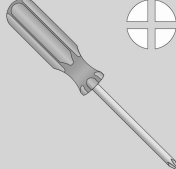
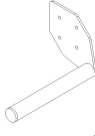

2

OPTIE - OPTION

		AC005027		4x	AC000204		20x
---	--	----------	---	----	----------	---	-----

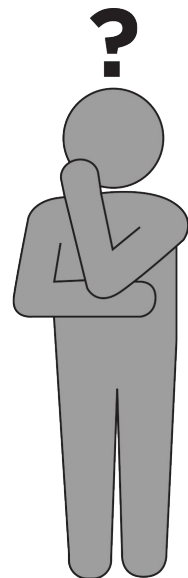
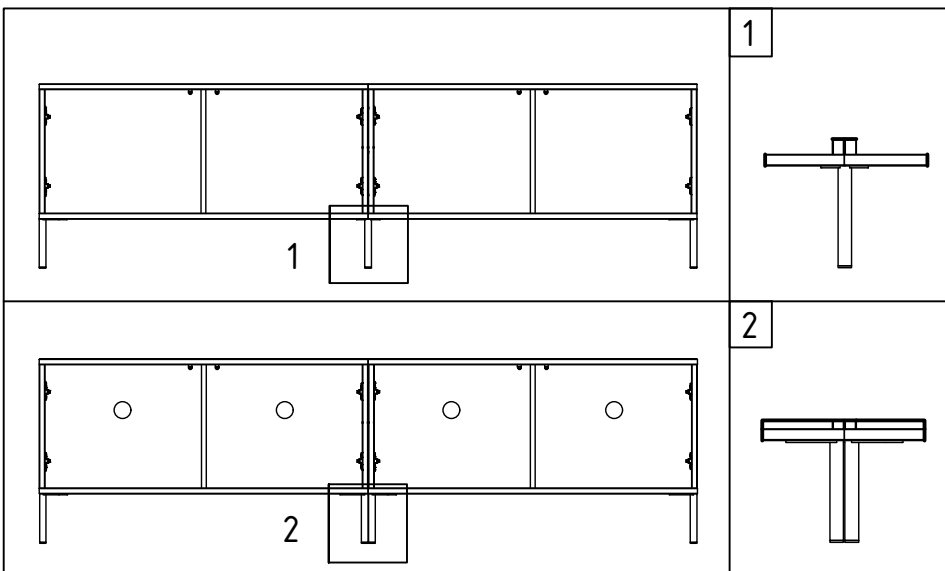
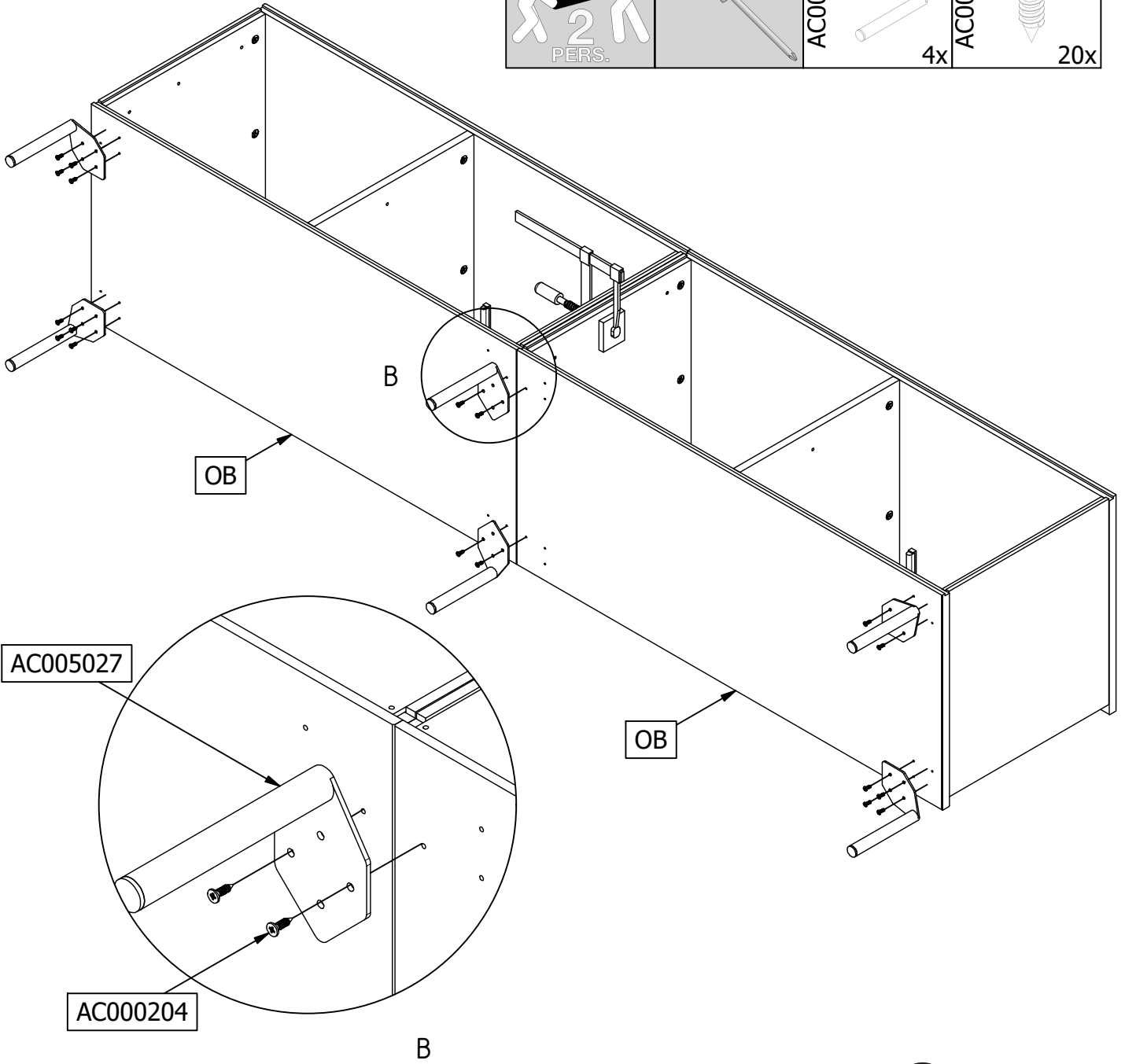

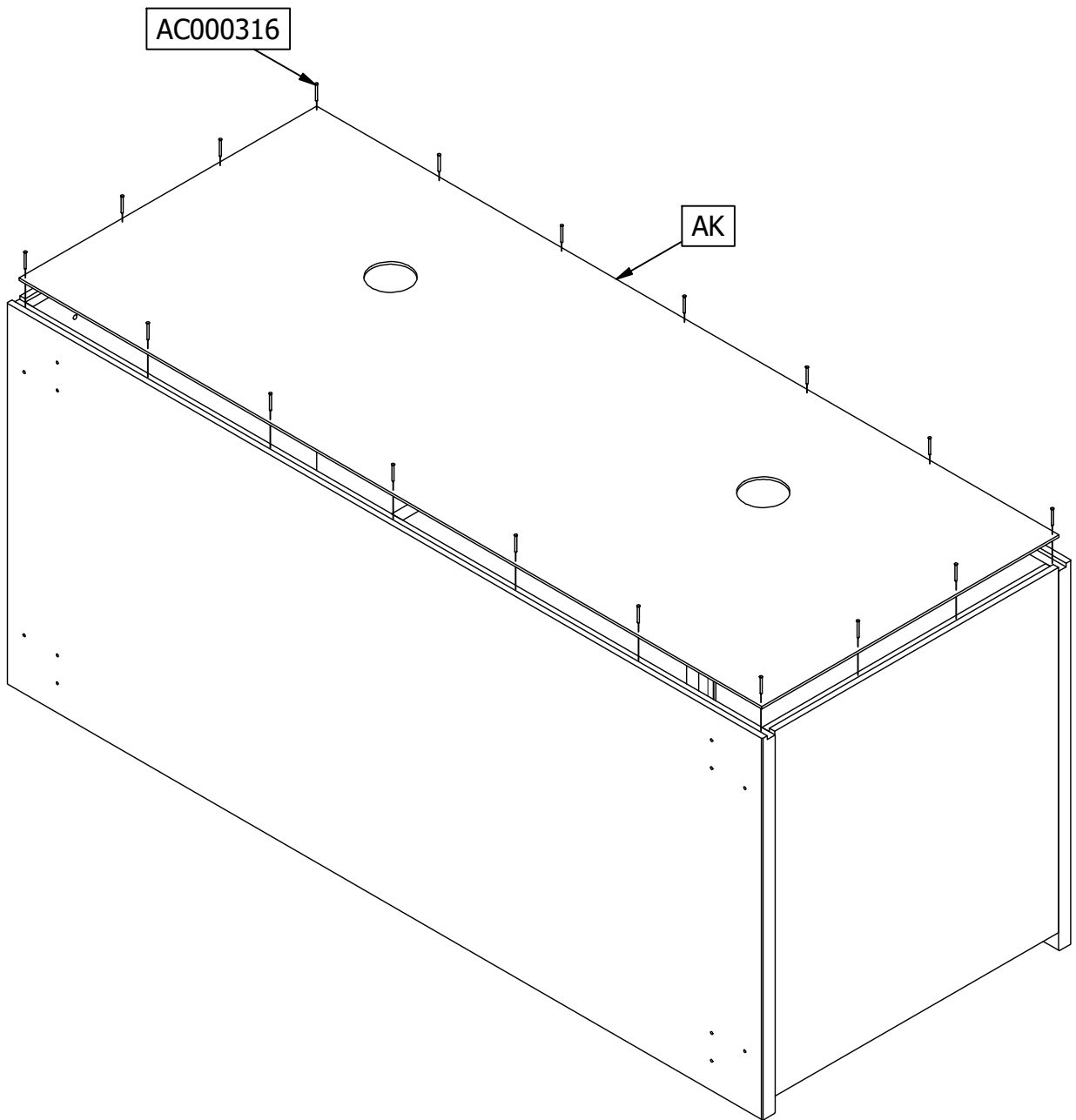
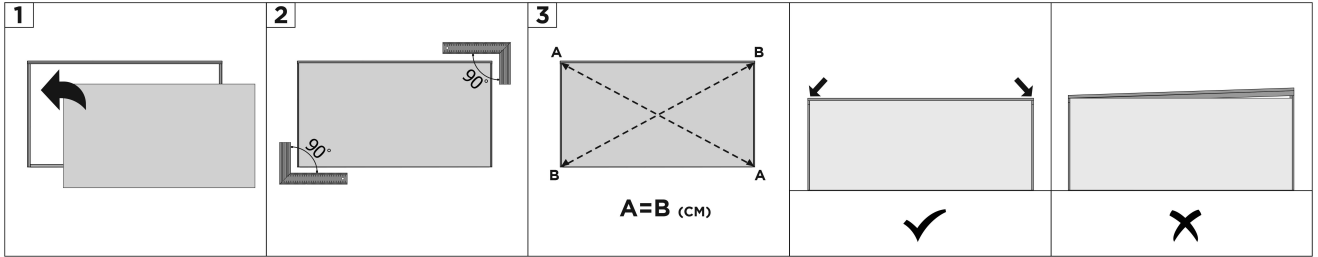
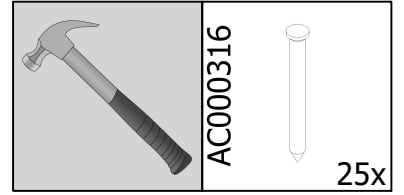

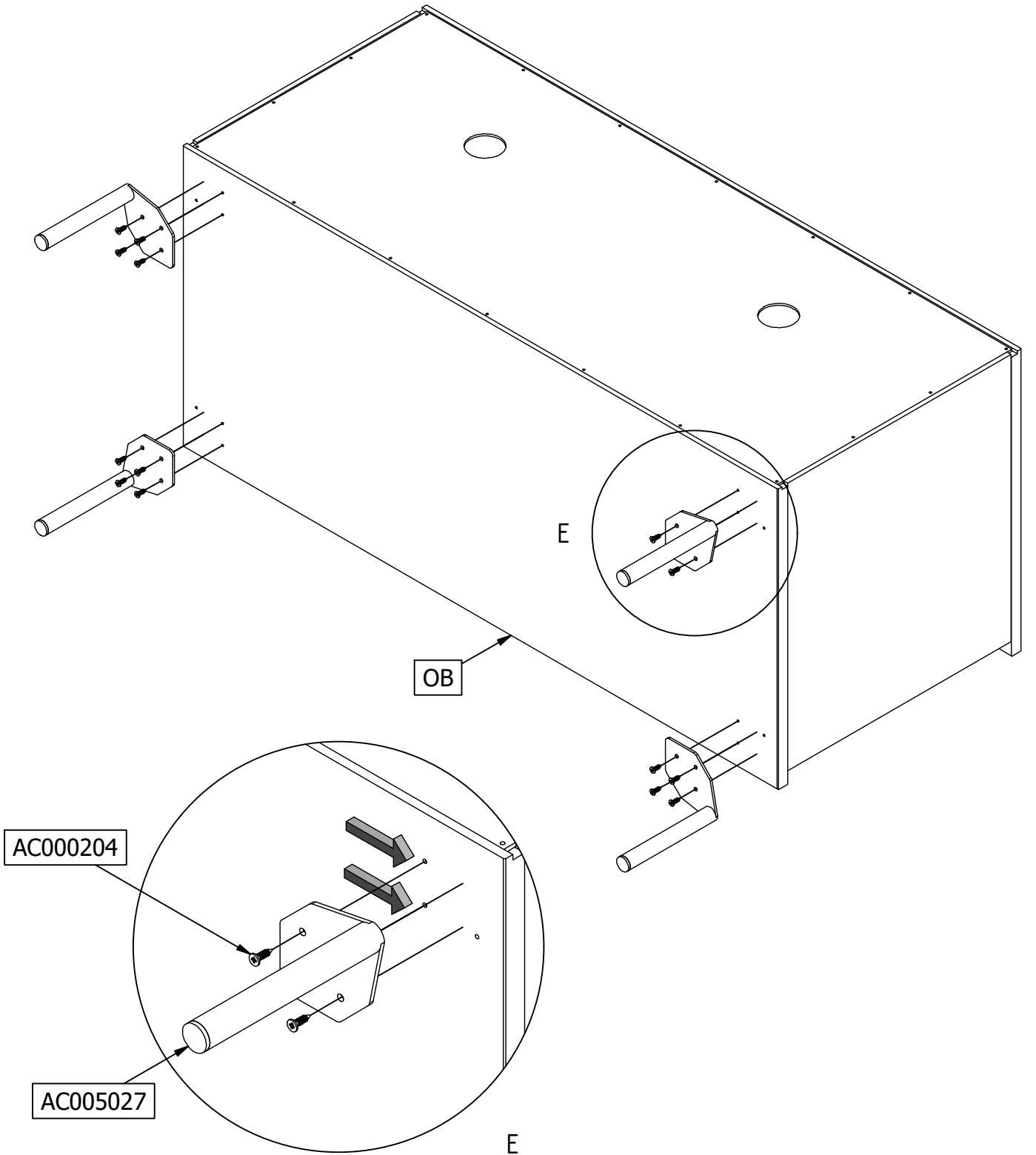
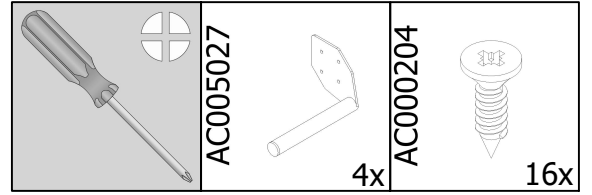

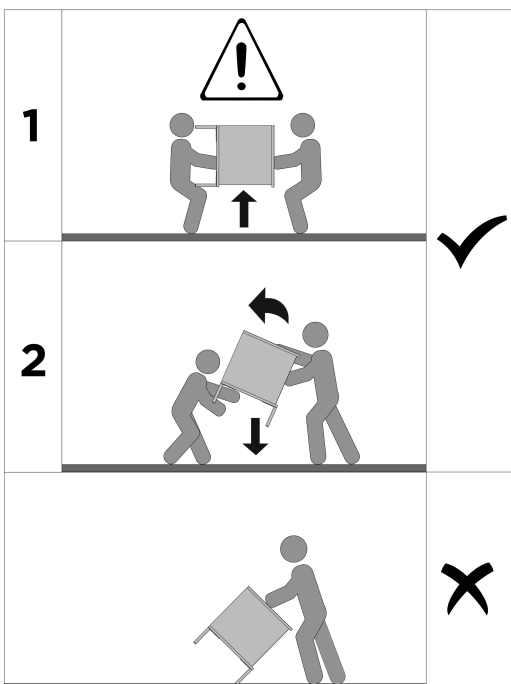
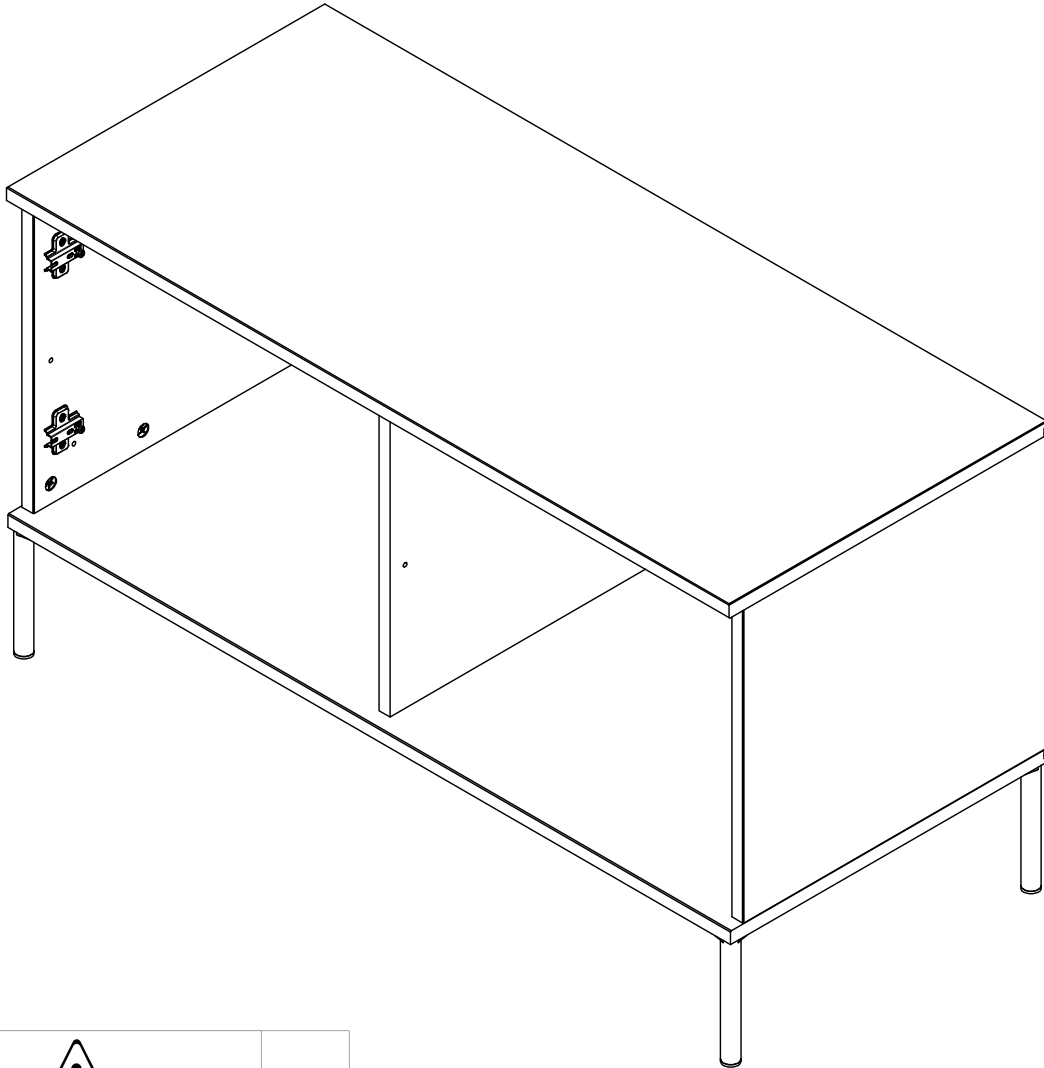

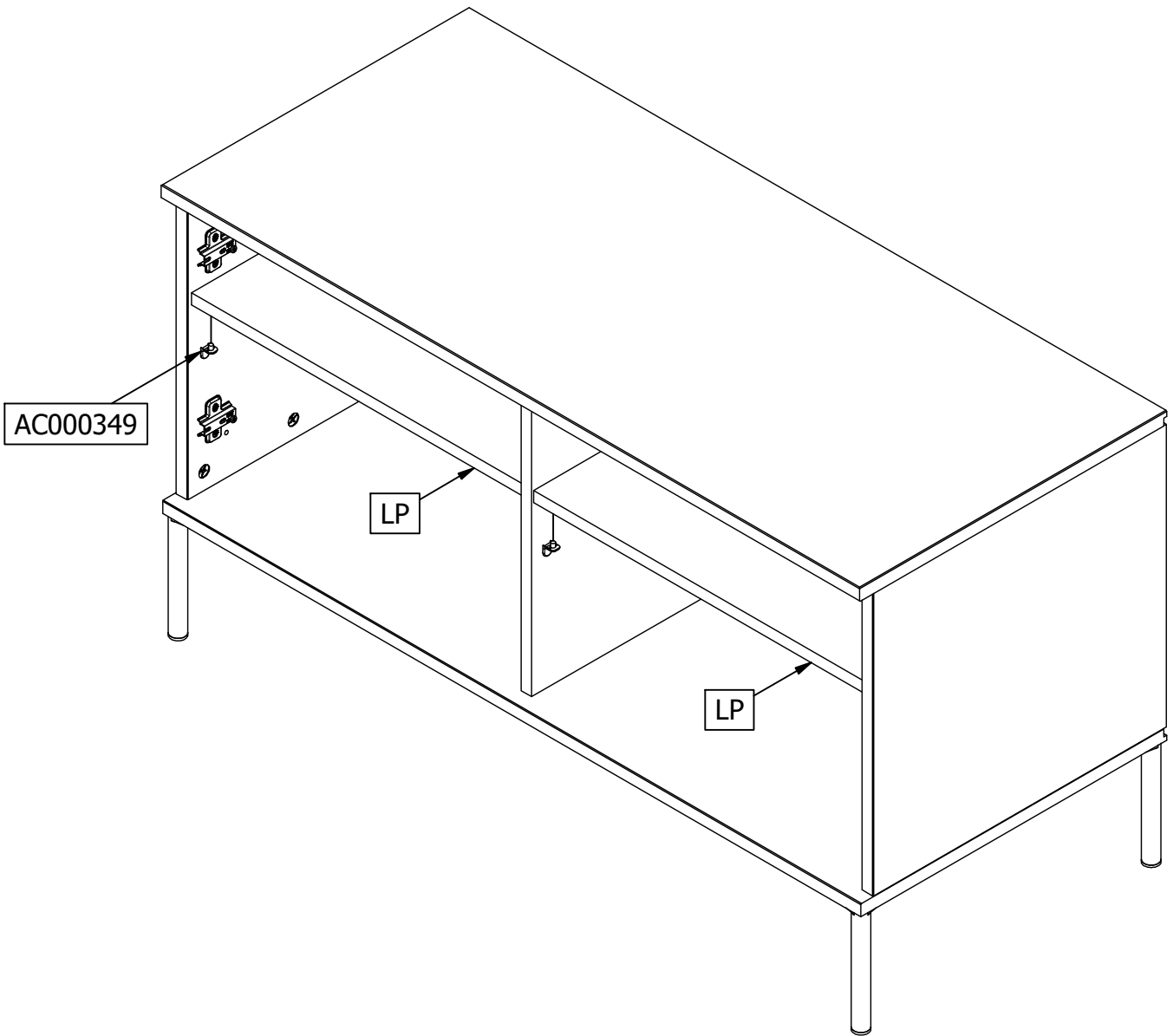
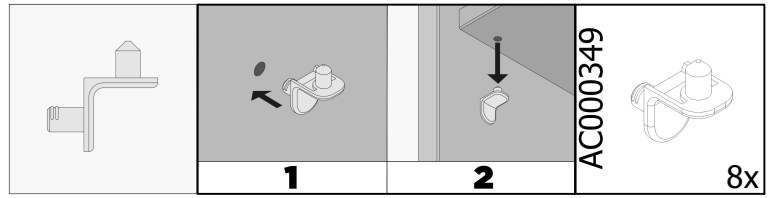

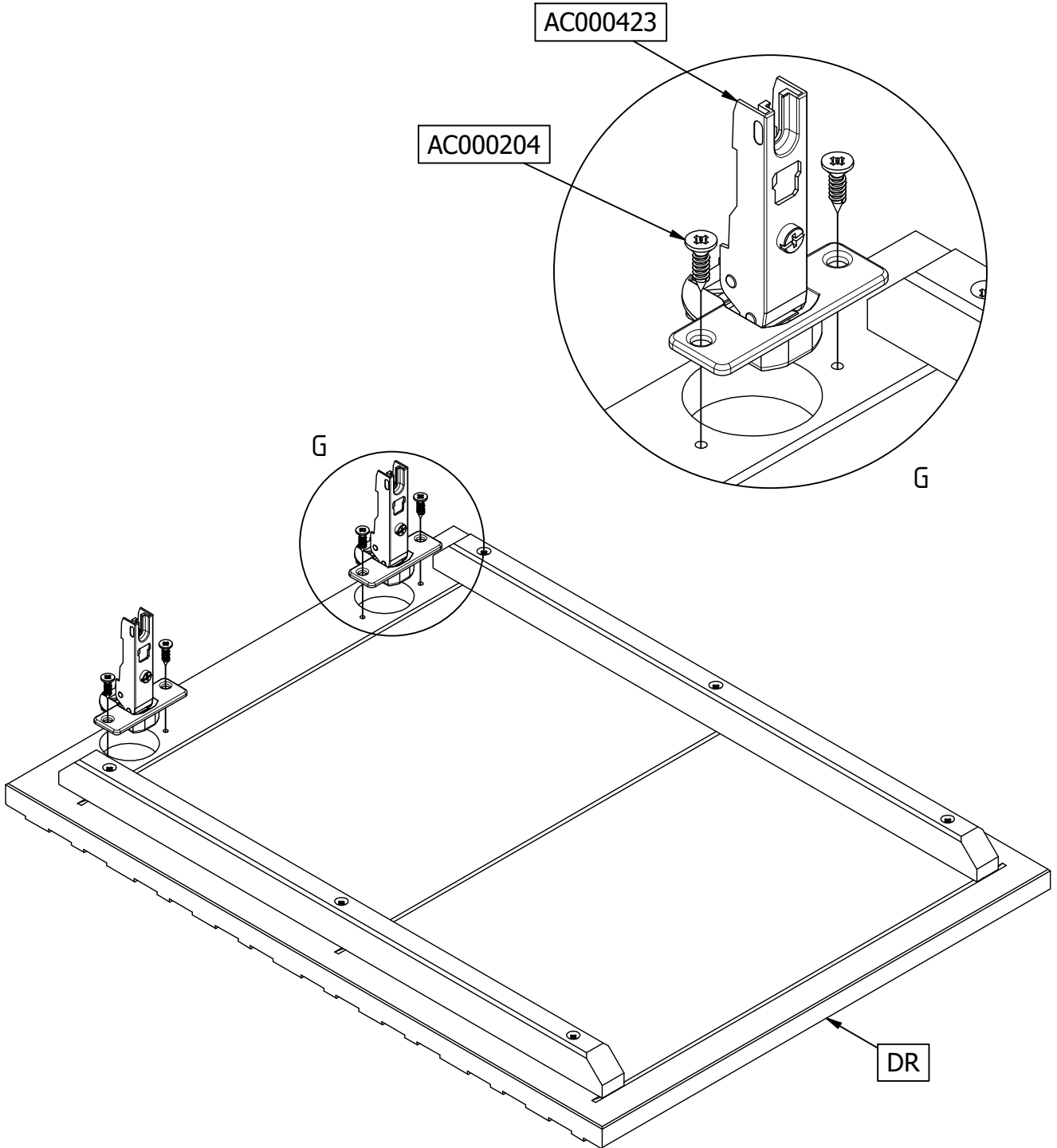
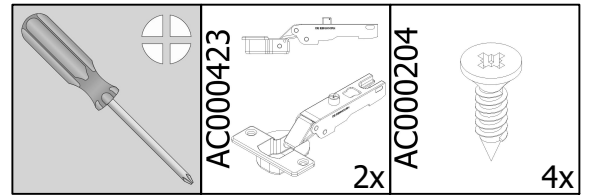

2x

15

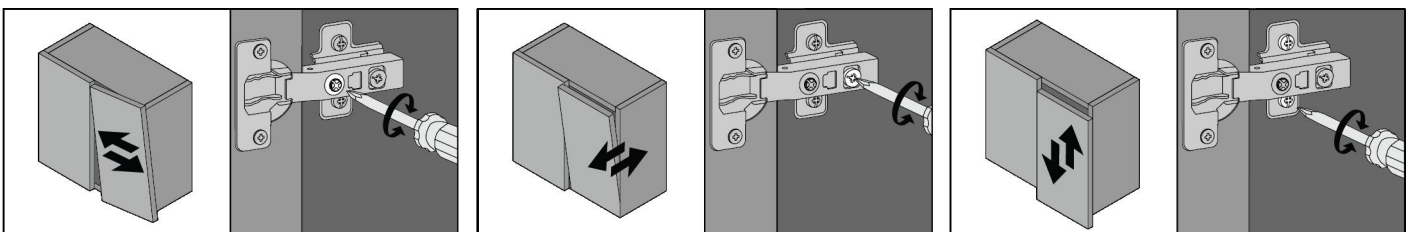
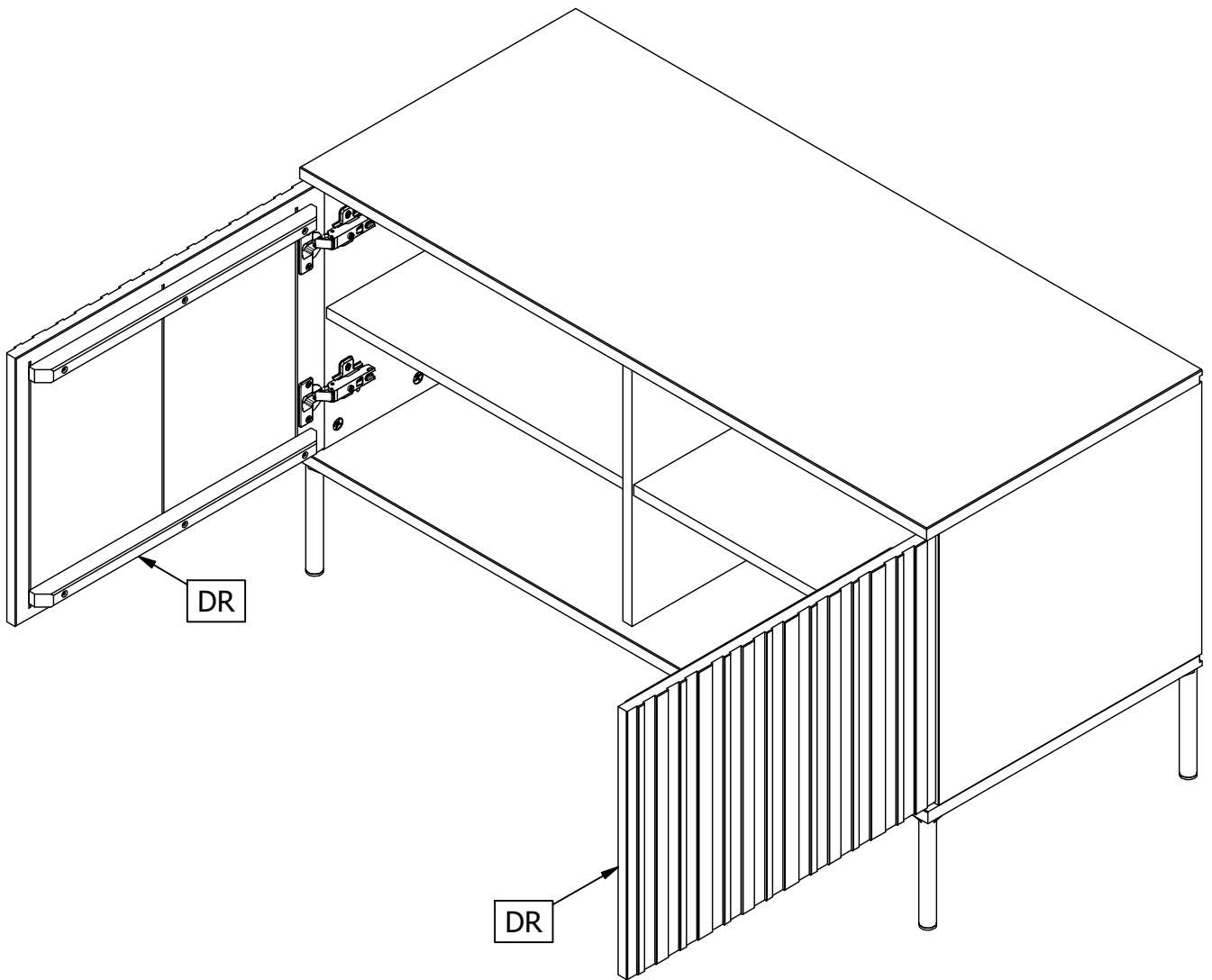
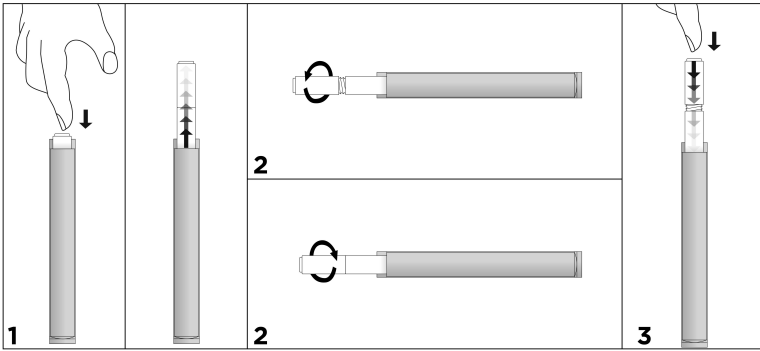
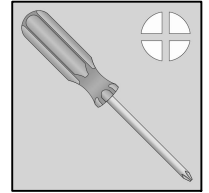

16

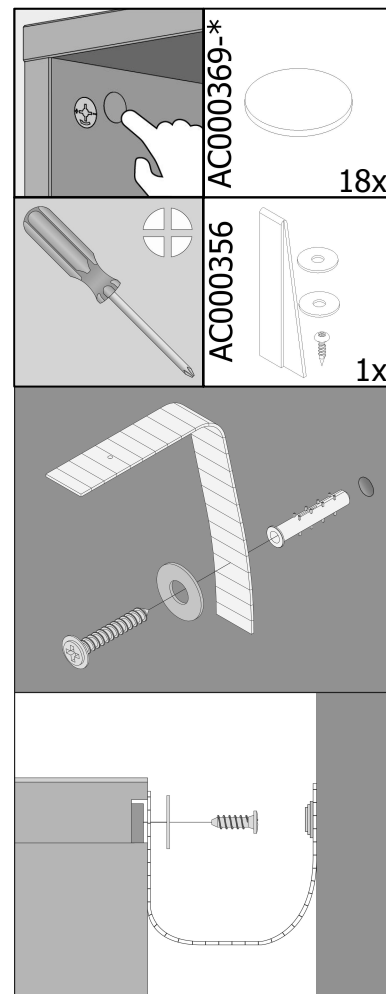
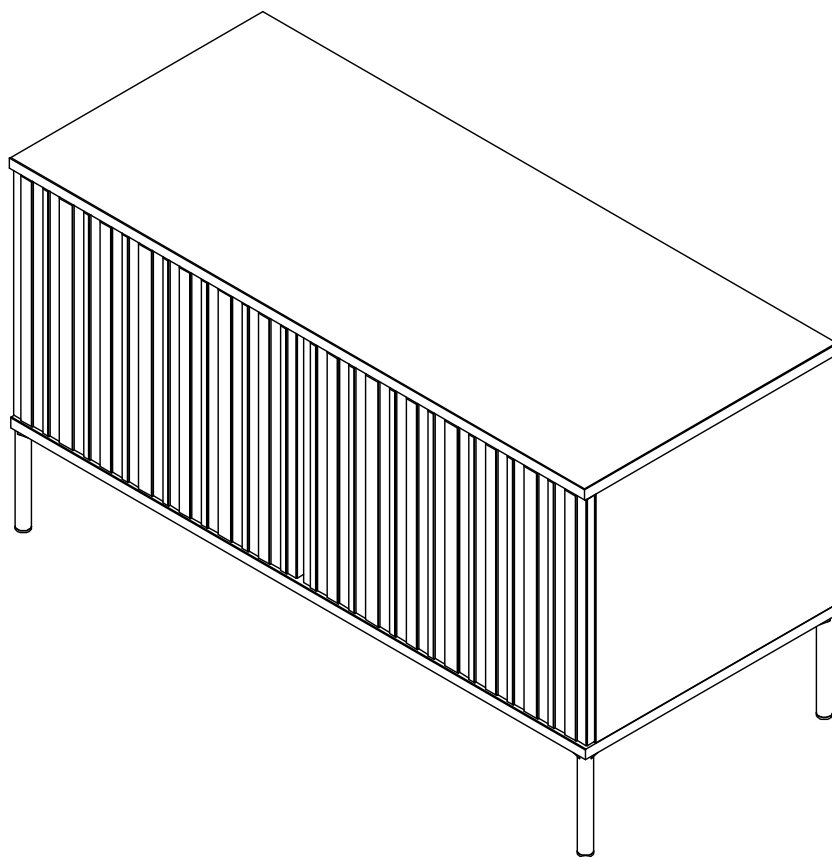
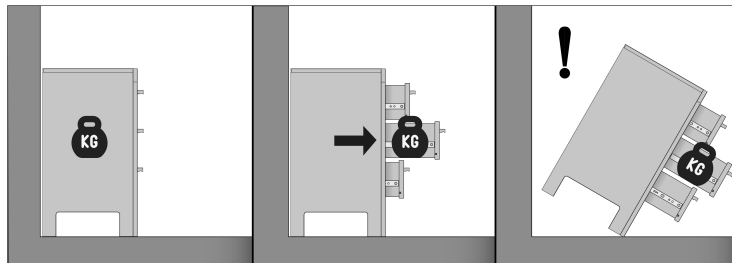

SOCIAL MEDIA

We zijn benieuwd naar het resultaat! Mocht je het met ons willen delen, gebruik #WOOOD op social media.
We are curious about the result! Would you like to share it with us? Use #WOOOD on social media.
Wir sind gespannt auf das Ergebnis! Möchten Sie es mit uns teilen? Benutzen Sie #WOOOD in Social Media.
Nous sommes impatient de connaître le résultat. Souhaitez-vous le partager avec nous? Utilisez #WOOOD sur les médias sociaux.



facebook.com/wood.nl
instagram.com/madebywood
pinterest.com/madebywood